



**Hidro  
Pnevmo  
Tehnika**

3, Vojeli St., Kazanlak, Bulgaria  
Tel.: +359 431/62 228  
Fax.: +359 431/62 019  
e-mail: [info@hpt-bg.com](mailto:info@hpt-bg.com)  
[www.hpt-bg.com](http://www.hpt-bg.com)

## HYDRAULIC MOTOR BLOCKS TYPE BD

**BDS 1204 ./... .**

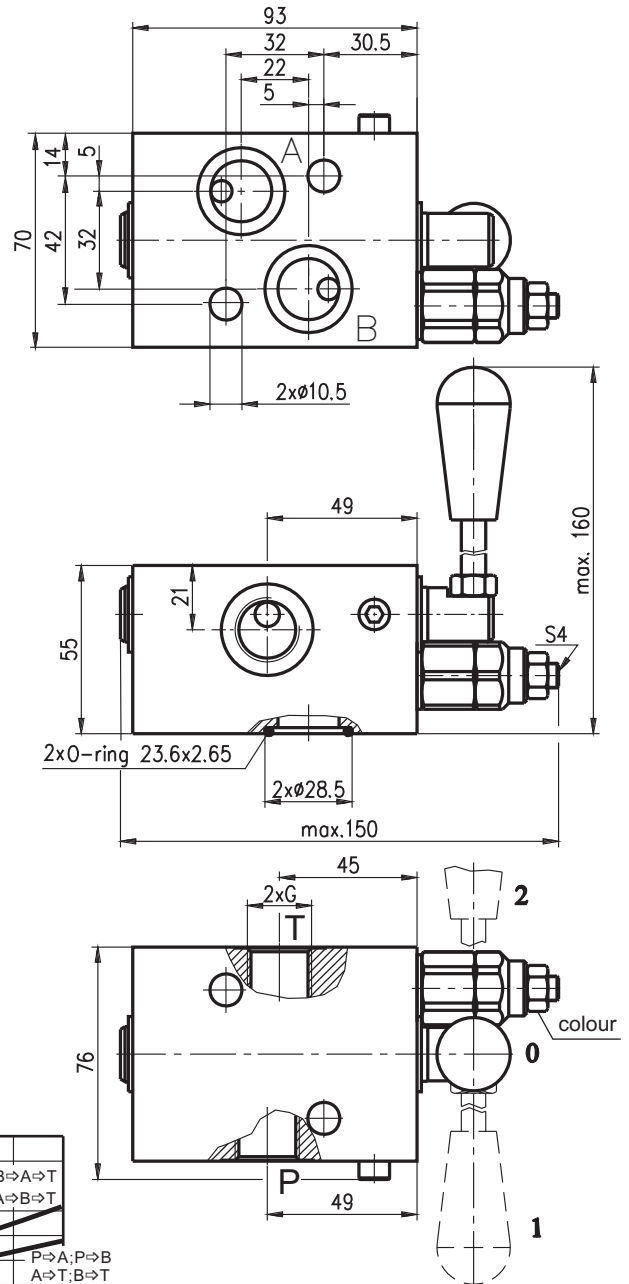
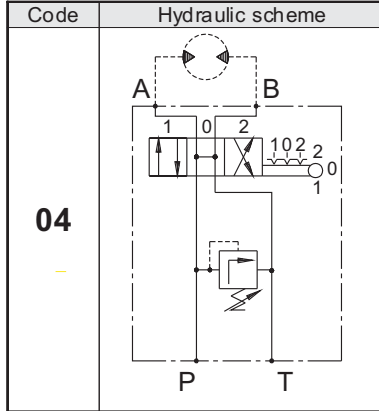

Pressure range			
Code	Standard setting (Q=5l/min)	Abj. pressure range	Colour
	bar	bar	-
<b>10</b>	80	10...100	White
<b>25</b>	180	30...250	Yellow

Code	Adjustments
<b>A</b>	Leakproof hex. socket screw
<b>B</b>	Handknob and locknut
<b>C</b>	Sealing cap

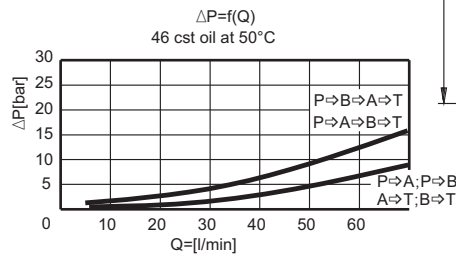

Type	Nom. flow rate L/min	P <sub>max.</sub> bar	Port threads G
<b>BDS 1204 ./... .</b>	60	250	G1/2 - DIN 3852

### ORDERING CODE

**BD S 12 04 L / 10 A**

Type

Hydraulic motor type - code:  
MS - **S**

Port threads G - code:  
G1/2 - **12**

Code scheme:  
**04**

Body material - code:  
Aluminium - **Omit**  
Brass - **L**

Code adjustments:  
**A; B; C**  
(see table above)

Pressure range code:  
**10; 25**