



**Hidro
Pnevmo
Tehnika**

3, Vojeli St., Kazanlak, Bulgaria
Tel.: +359 431/62 228
Fax.: +359 431/62 019
e-mail: info@hpt-bg.com
www.hpt-bg.com

HYDRAULIC MOTOR BLOCKS TYPE BD

BDS 3807/... ..

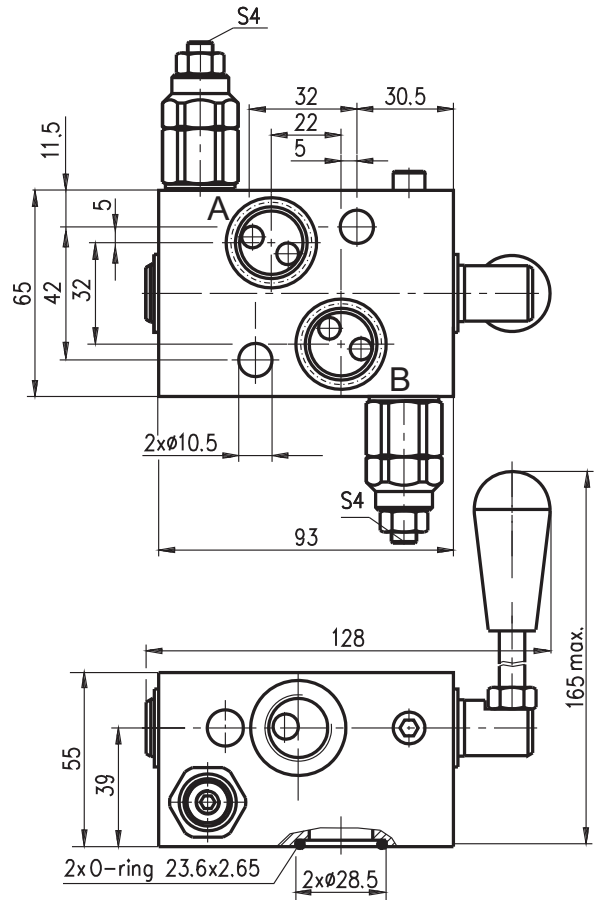
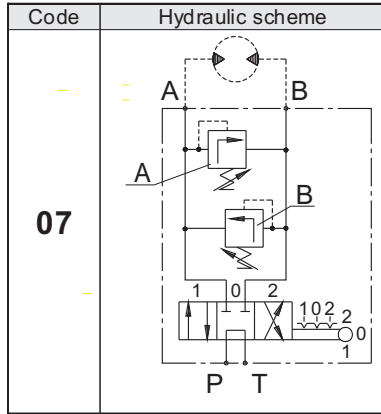
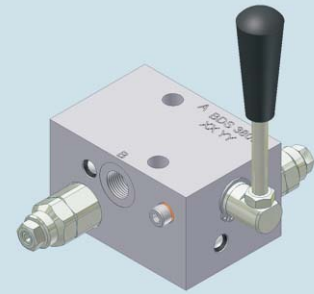

Code	Adjustments
A	Leakproof hex. socket screw
C	Sealing cap

Type	Nom. flow rate <i>L/min</i>	P _{max.} <i>bar</i>	Port threads G
BDS 3807 /... ..	25	250	G38 - DIN 3852

Pressure range			
Code	Standard setting (Q=5l/min) <i>bar</i>	Abj. pressure range <i>bar</i>	Colour
10	80	10...100	White
25	180	30...250	Yellow

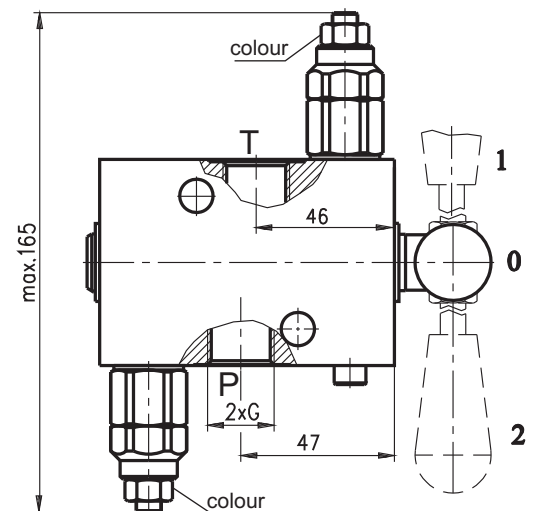

ORDERING CODE

BD S 38 07 / A10 A - B25 A

