



**Hidro
Pnevmo
Tehnika**

3, Vojeli St., Kazanlak, Bulgaria
Tel.: +359 431/62 228
Fax.: +359 431/62 019
e-mail: info@hpt-bg.com
www.hpt-bg.com

HYDRAULIC MOTOR BLOCKS TYPE BV

BVR 12 10/.. .

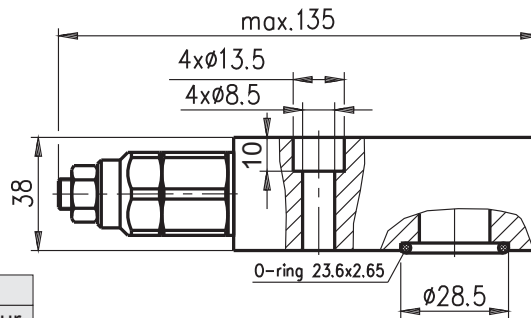
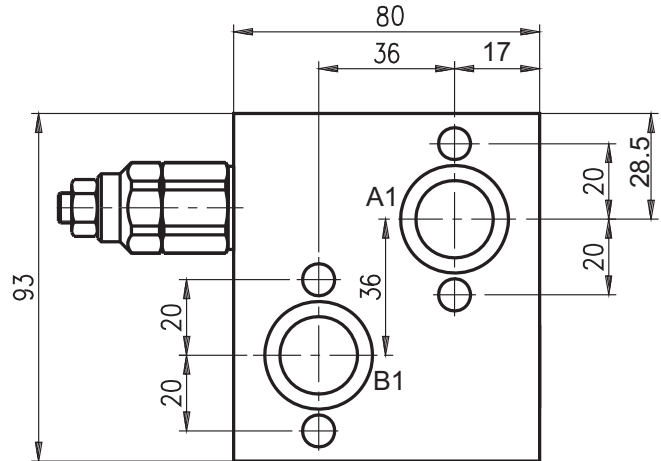
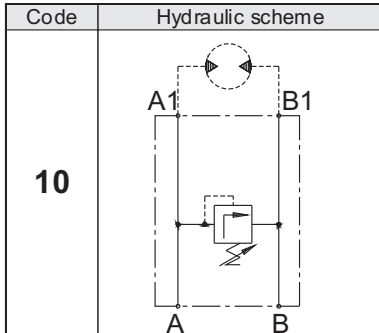
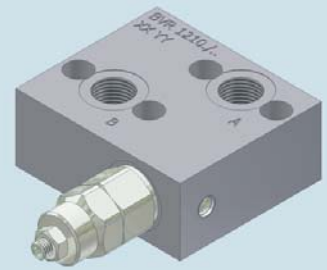

Pressure range			
Code	Standard setting (Q=5l/min)	Adj. pressure range	Colour
	bar	bar	
10	80	10...100	White
25	180	30...250	Yellow

Code	Adjustments
A	Leakproof hex. socket screw
B	Handknob and locknut
C	Sealing cap

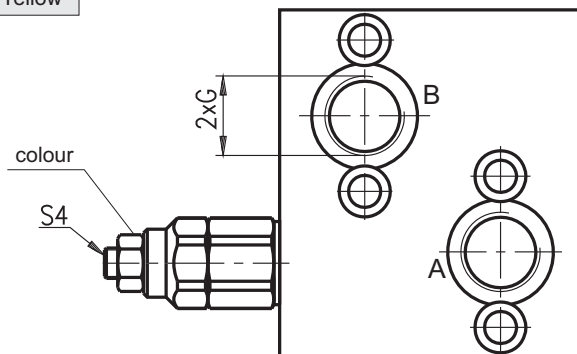

Type	Nom. flow rate	P _{max.}	Port threads G
	L/min	bar	-
BVR 1210 /... .	50	250	G1/2 - DIN 3852

ORDERING CODE

BV R 12 10 / 10 A

