

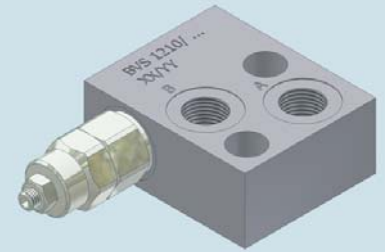

**Hidro  
Pnevmo  
Tehnika**

3, Vojvodi St., Kazanlak, Bulgaria  
Tel.: +359 431/62 228  
Fax.: +359 431/62 019  
e-mail: [info@hpt-bg.com](mailto:info@hpt-bg.com)  
[www.hpt-bg.com](http://www.hpt-bg.com)

## HYDRAULIC MOTOR BLOCKS TYPE BV



**BVS 12 10/..**

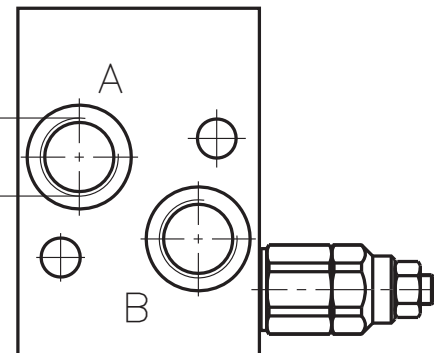
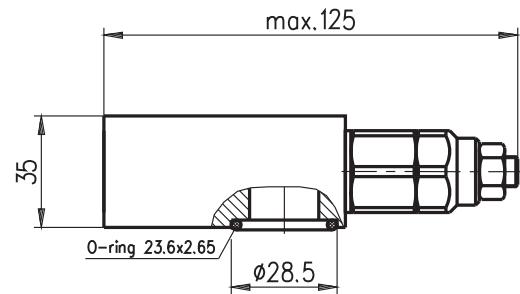
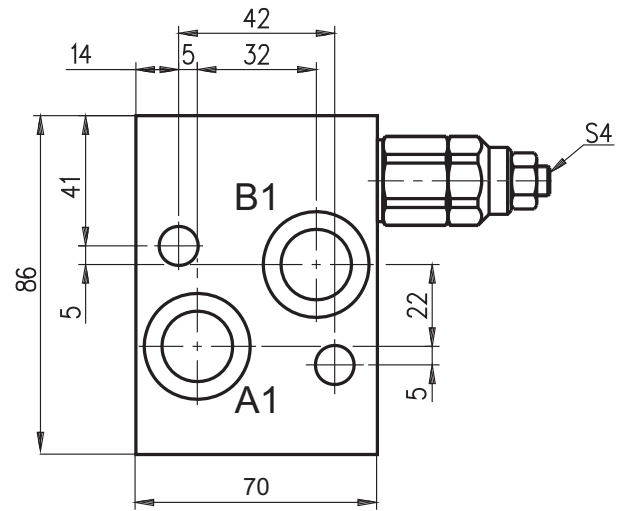
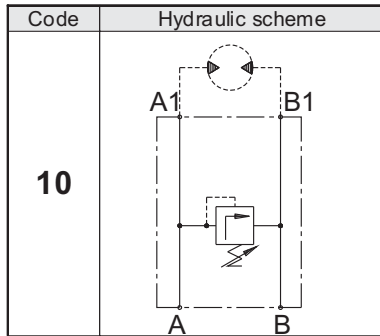

Pressure range			
Code	Standard setting (Q=5l/min)		Colour
	bar	Adj. pressure range bar	
10	80	10...100	White
25	180	30...250	Yellow

Code	Adjustments
A	Leakproof hex. socket screw
B	Handknob and locknut
C	Sealing cap

Type	Nom. flow rate	P <sub>max.</sub>	Port threads G
	L/min	bar	-
BVS 1210 /... .	50	250	G1/2 - DIN 3852

### ORDERING CODE

**BV S 12 10 / 10 A**

