



**Hidro
Pnevmo
Tehnika**

3, Vojeli St., Kazanlak, Bulgaria
Tel.: +359 431/62 228
Fax.: +359 431/62 019
e-mail: info@hpt-bg.com
www.hpt-bg.com

HYDRAULIC MOTOR BLOCKS TYPE BV

BVT 34 07

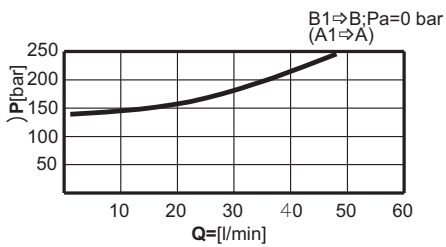
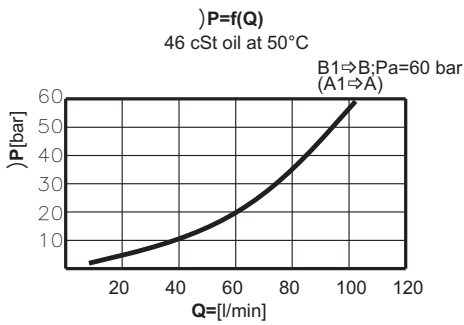
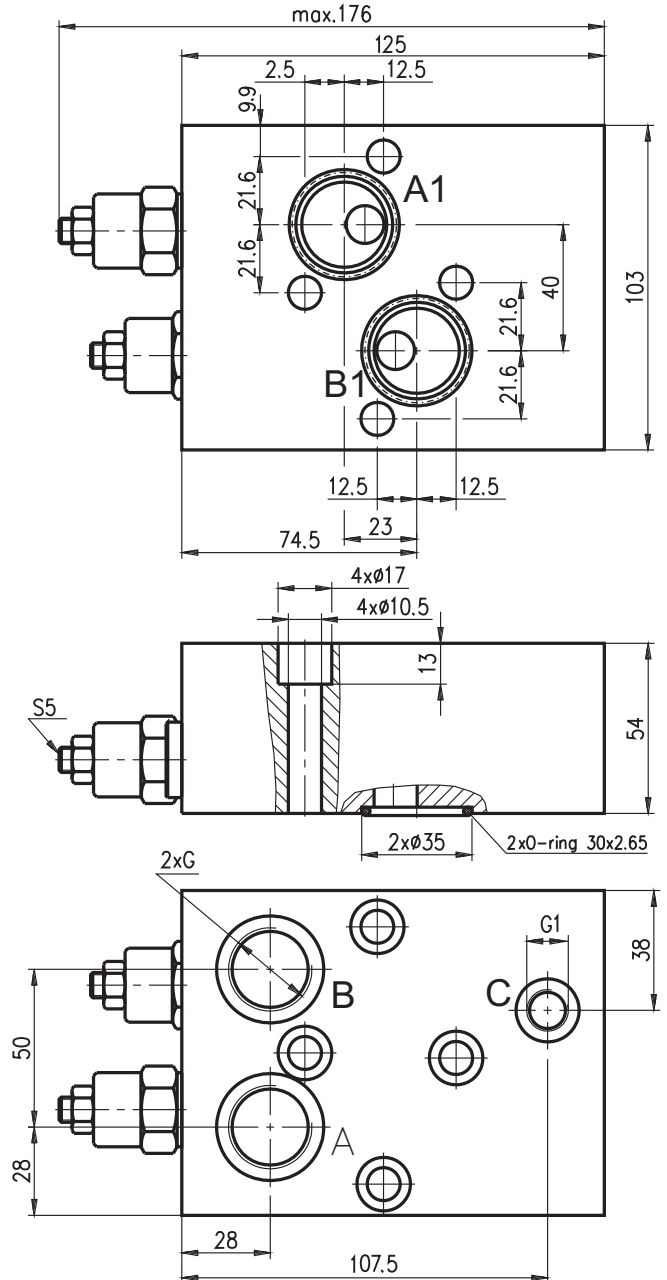
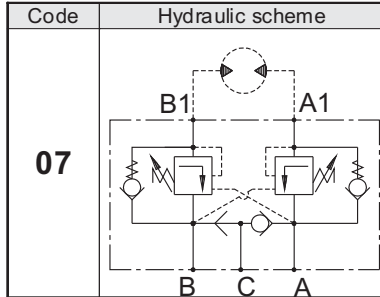

Type	Nominal flow rate	Adj. pressure range	Pressure ratio	P _{max.}	Port threads G	Port threads G1
	L/min	bar	-	bar	-	-
BVT 3407	100	60...250	4,25:1	250	G3/4 - DIN 3852	G1/4 - DIN 3852
BVT 111607	100	60...250	4,25:1	250	1 1/16-12UN - ISO 11926	7/16-20UNF - ISO 11926
BVT 2707	100	60...250	4,25:1	250	M27x2 - DIN 3852	M14x1,5 - DIN 3852

ORDERING CODE

BV T 34 07

