



**Hidro
Pnevmo
Tehnika**

3, Vojeli St., Kazanlak, Bulgaria
Tel.: +359 431/ 62 228, 68 440
e-mail: info@hpt-bg.com
www.hpt-bg.com

HYDRAULIC MOTOR BLOCKS TYPE BV

BVR .. 07

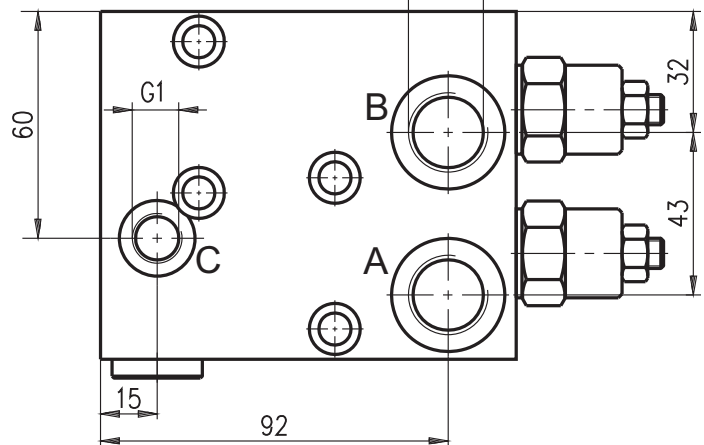
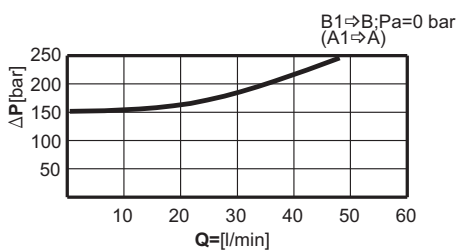
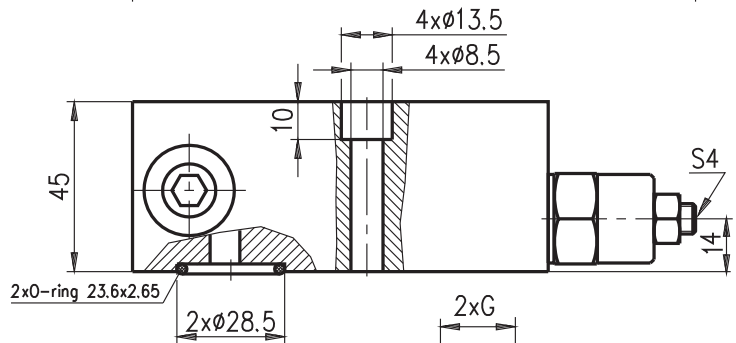
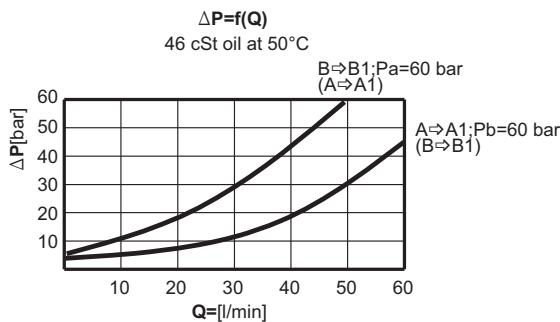
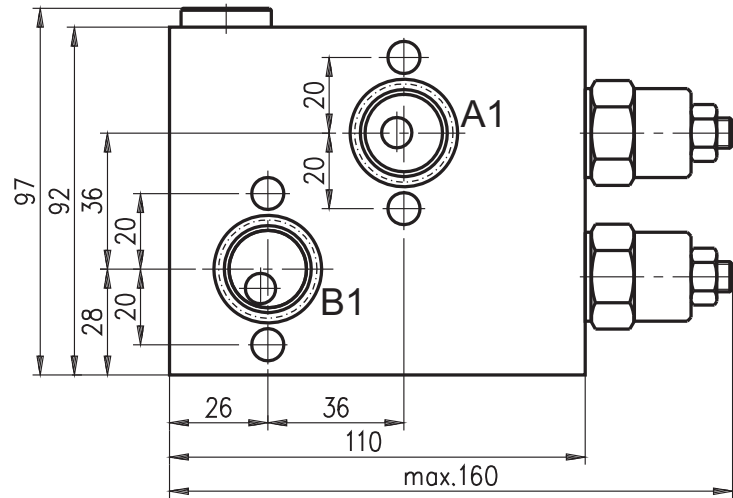
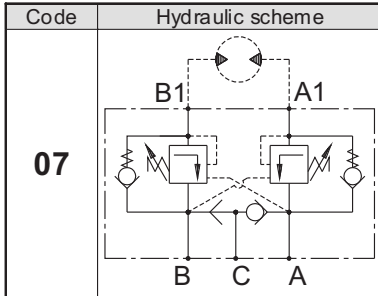

Type	Nominal flow rate	Adj. pressure range	Pressure ratio	P _{max.}	Port threads G	Port threads G1
	L/min	bar	-	bar	-	-
BVR 1207	60	60...250	4,25:1	250	G1/2 - DIN 3852	G1/4 - DIN 3852
BVR 7807	60	60...250	4,25:1	250	7/8-14UNF - ISO 11926	7/16-20UNF - ISO 11926
BVR 2207	60	60...250	4,25:1	250	M22x1,5 - DIN 3852	M14x1,5 - DIN 3852

ORDERING CODE

BV R 12 07 D

