



**Hidro
Pnevmo
Tehnika**

3, Vojeli St., Kazanlak, Bulgaria
Tel.: +359 431/ 62 228, 68 440
e-mail : info@hpt-bg.com
www.hpt-bg.com

**SINGLE OVERCENTER VALVE
WITH EXTERNAL PILOT-
NIPPLE SCREW FLANGEABLE**

OWC/SE-38/..M

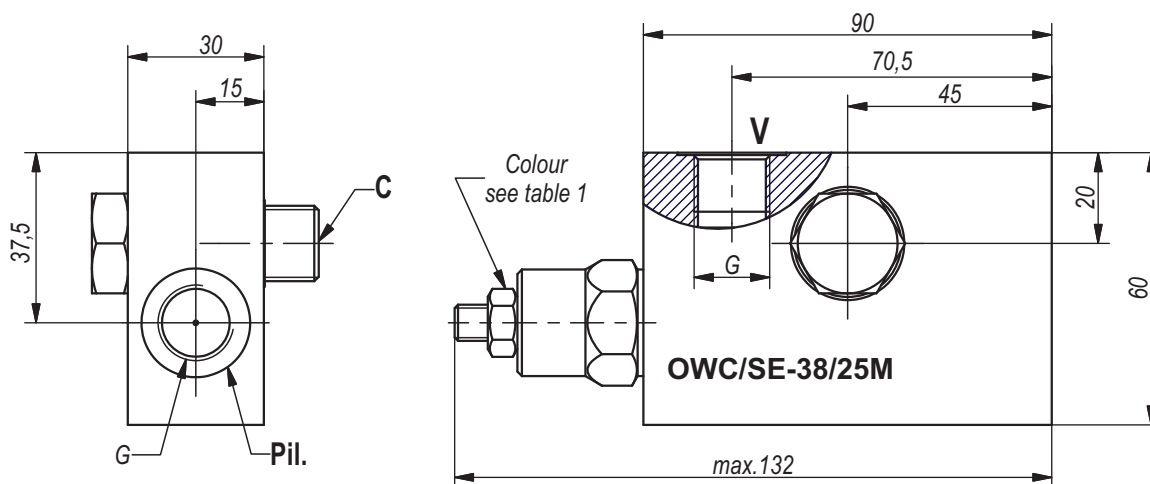
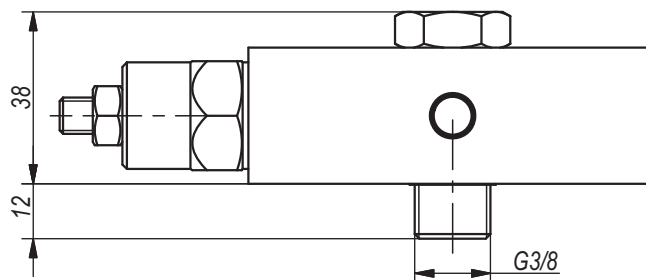
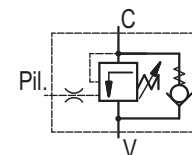

Table 1

Code	Pressure range		Pilot ratio	Colour
	Standard setting (Q=5l/min) bar	Adj. pressure range bar		
25	100	60...250	4,26:1	White
35	250	100...350	4,26:1	Yellow

Table 2

Type	Q nom.	G	Body material
	L/min.		
OWC/SE-38/25M	35	G3/8"-DIN 3852	Aluminium
OWC/SE-38/35M	35	G3/8"-DIN 3852	Steel

All performances and calibration are carried out by using hydraulic oil with viscosity approx. 46 cSt at 50°C.

Working fluid - mineral oil with:
- viscosity - 10...100 cSt;
- temperature - -20...+80°C;
- filtration level - 25 μm.

ORDERING CODE

OWC/SE - 38/25 M

